



Università degli Studi di Pavia
Facoltà di Ingegneria

Corso di Principi e Applicazioni di Elettrotecnica

Regime P.A.S.



Regime P.A.S.

■ REGIME PERIODICO ALTERNATO SINUSOIDALE (P.A.S.)

E' un caso particolare di regime variabile
Le grandezze elettriche (tensione, corrente)
sono del tipo

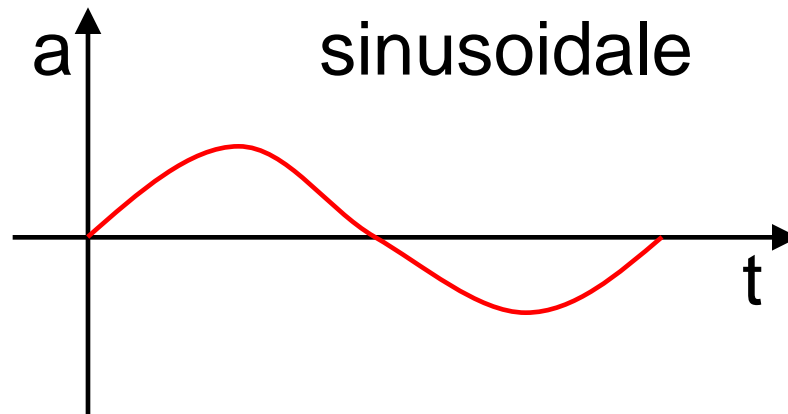



Regime P.A.S.

■ REGIME PERIODICO ALTERNATO SINUSOIDALE (P.A.S.)

Il regime P.A.S. ha un posto predominante perchè:

- la potenza elettrica e i segnali elettrici si trasmettono generalmente in P.A.S.
- è facile generare e ancor più facile trasmettere ed è utile convertire la potenza elettrica in P.A.S.
- un qualunque segnale periodico è riconducibile alla somma di infiniti segnali P.A.S.



Regime P.A.S.

■ GRANDEZZA P.A.S.

$a(t)$ oppure $a(\theta)$; $\theta = \omega t$

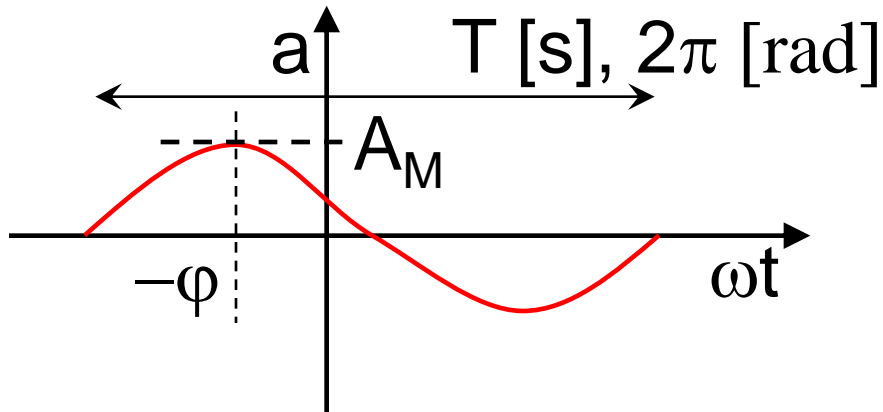

$$a(\theta) = A_M \cos(\theta + \varphi)$$

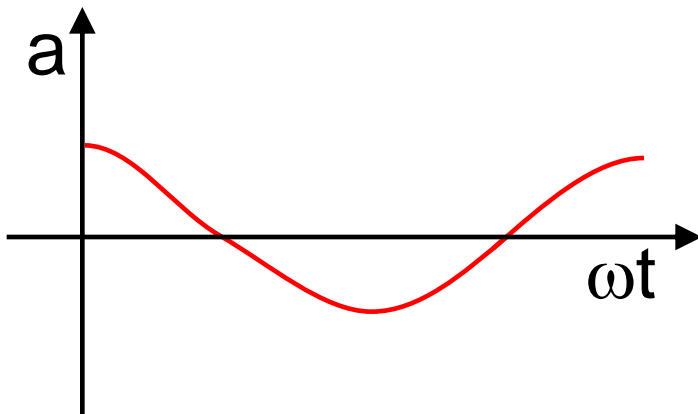

Valore medio

$$A_m = \frac{1}{2\pi} \int_0^{2\pi} A_M \cos(\theta) d\theta = 0$$



Regime P.A.S.

■ GRANDEZZA P.A.S.

Valore medio aritmetico

$$\begin{aligned} A_{\text{ma}} &= \frac{1}{2\pi} \int_0^{2\pi} A_M |\cos(\theta)| d\theta = \frac{1}{2\pi} 4 \int_0^{\pi/2} A_M \cos(\theta) d\theta = \\ &= \frac{1}{2\pi} 4A_M [\sin(\theta)]_0^{\pi/2} = \frac{2A_M}{\pi} \end{aligned}$$

Valore efficace

$$A = \sqrt{\frac{1}{2\pi} \int_0^{2\pi} A_M^2 \cos^2(\theta) d\theta} = \sqrt{\frac{1}{2\pi} A_M^2 \frac{1}{2} 2\pi} = \frac{A_M}{\sqrt{2}}$$



Regime P.A.S.

■ GRANDEZZA P.A.S.

Fattore di vertice

$$k_v = \frac{A_M}{A} = \sqrt{2} = 1.41$$

Fattore di forma

$$k_f = \frac{A}{A_{ma}} = \frac{A_M}{\sqrt{2}} \frac{\pi}{2A_M} = \frac{\pi}{2\sqrt{2}} = 1.11$$



Regime P.A.S.

■ GRANDEZZA P.A.S.

Significato di valore efficace di una grandezza periodica (tensione o corrente), ad esempio ai morsetti di un resistore lineare di resistenza R .

La potenza istantanea $p(t) = v(t)i(t) = Ri^2(t) = v^2(t)/R$ è anche periodica e il suo valor medio P :

$$P = \frac{1}{T} \int_0^T p(t) dt = \frac{R}{T} \int_0^T i^2(t) dt = R \left(\sqrt{\frac{1}{T} \int_0^T i^2(t) dt} \right)^2 = RI^2 = \frac{V^2}{R}$$



Regime P.A.S.

■ RAPPRESENTAZIONE DELLE GRANDEZZE P.A.S.

Nel dominio di t , θ

$$\theta = \omega t, \quad \omega = 2\pi/T$$
$$f = 1/T, \quad \omega = 2\pi f$$

rapp. grafica

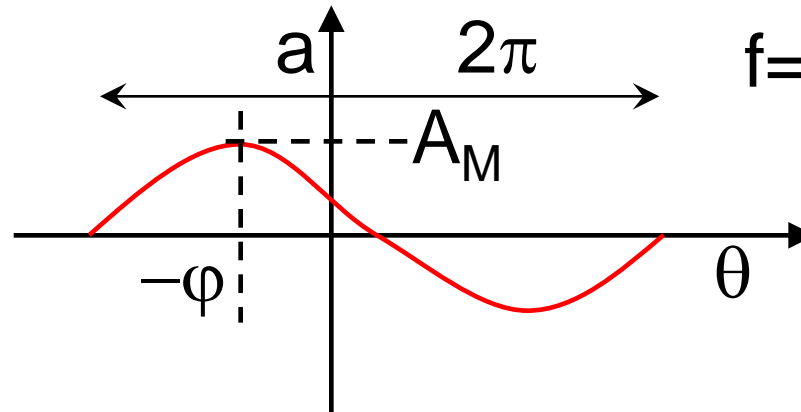

rapp. analitica

$$a(t) = A_M \cos(\omega t + \varphi)$$



Regime P.A.S.

■ RAPPRESENTAZIONE DELLE GRANDEZZE P.A.S.

Osservazione: una grandezza P.A.S. è individuata da 3 grandezze reali:

- T oppure f oppure $\omega = 2\pi f = \frac{2\pi}{T}$

- A_M oppure $A = \frac{A_M}{\sqrt{2}}$ oppure $A_{ma} = \frac{2A_M}{\pi}$

- φ oppure $\tau = \frac{\varphi}{\omega}$



Regime P.A.S.

■ RAPPRESENTAZIONE DELLE GRANDEZZE P.A.S.

La rappresentazione delle grandezze P.A.S. nel dominio del tempo è complicata.

Si cerca una rappresentazione equivalente più semplice:

1) TRASFORMAZIONE (Steinmetz, 1908)

funzione di t
 $a(t)$

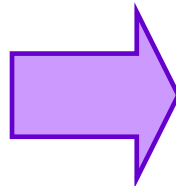

fasore rotante
A



Regime P.A.S.

■ RAPPRESENTAZIONE DELLE GRANDEZZE P.A.S.

Rappresentazione polare

Coordinate polari $(0, x)$, vettore di ampiezza A , rotante a velocità ω in verso antiorario a partire dalla posizione φ

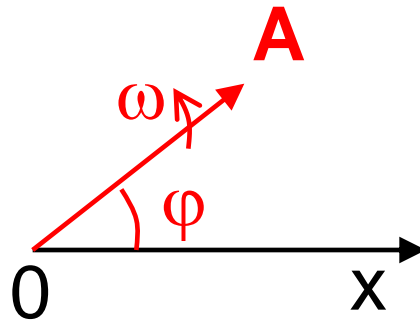

$$\mathbf{A} = (A, \omega, \varphi) = A e^{j(\omega t + \varphi)}$$

$$j = \sqrt{-1}$$



Regime P.A.S.

■ RAPPRESENTAZIONE DELLE GRANDEZZE P.A.S.

Rappresentazione cartesiana

Coordinate cartesiane (x,y) , numero complesso di modulo A e argomento $\omega t + \varphi$

$$j = \sqrt{-1}$$

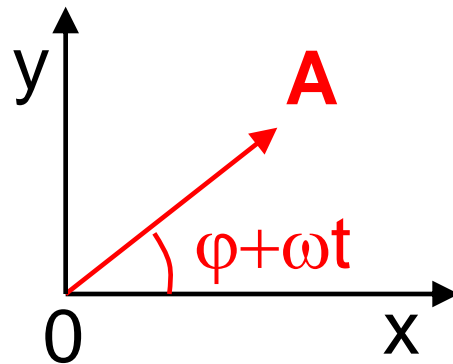

$$\mathbf{A} = A \cos(\omega t + \varphi) + j A \sin(\omega t + \varphi)$$

Regime P.A.S.

■ RAPPRESENTAZIONE DELLE GRANDEZZE P.A.S.

2) ANTITRASFORMAZIONE

fasore rotante
A

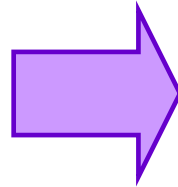

funzione di t
 $a(t)$

Rappresentazione polare

Coordinate polari: proiezione di
vettore rotante sull'asse (0,x)
(a meno del fattore $\sqrt{2}$)

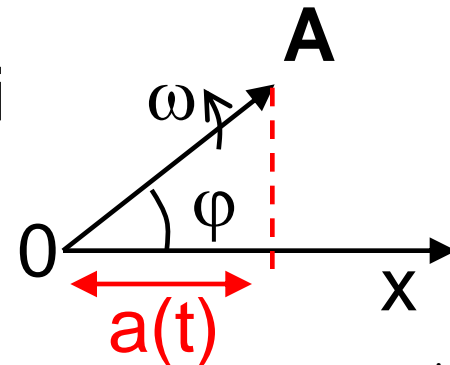



Regime P.A.S.

■ RAPPRESENTAZIONE DELLE GRANDEZZE P.A.S.

Rappresentazione cartesiana

Coordinate cartesiane: parte reale del numero complesso (a meno del fattore $\sqrt{2}$)

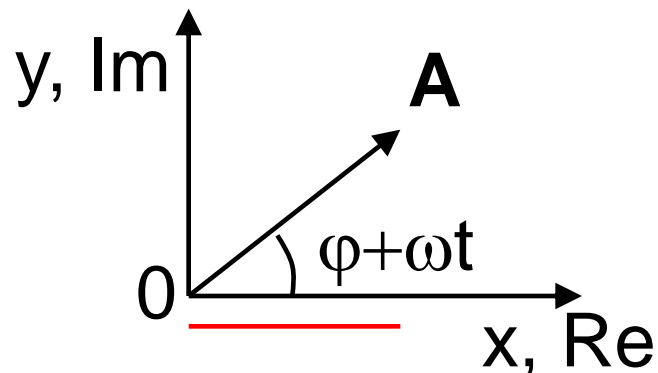

$$a(t) = \text{Re}(\mathbf{A}) = A \cos(\omega t + \varphi)$$

Regime P.A.S.

■ RAPPRESENTAZIONE DELLE GRANDEZZE P.A.S.

Se si prescinde da ω (ovvero f , T) perché nota o uguale per tutte le grandezze

$a(t)$ \longleftrightarrow fasore fisso

Rappresentazione grafica

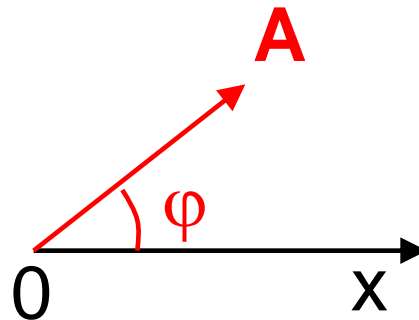

$$\mathbf{A} = (A, \varphi) = Ae^{j\varphi}$$

Regime P.A.S.

■ RAPPRESENTAZIONE DELLE GRANDEZZE P.A.S.

Rappresentazione analitica

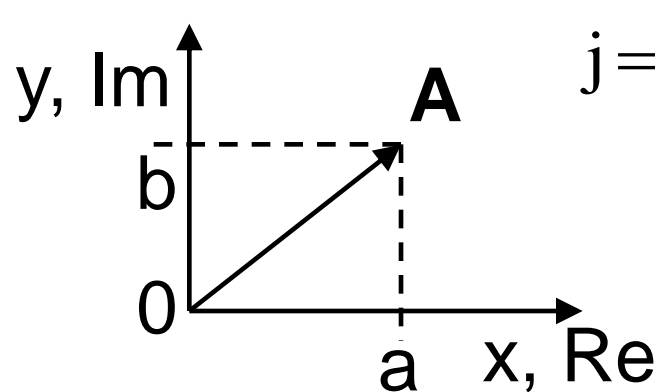

In **forma polare**

$$\mathbf{A} = A e^{j\varphi} = A \angle \varphi$$

$$e^{j\varphi} = \cos\varphi + j \sin\varphi$$

In **forma cartesiana**

$$\mathbf{A} = a + jb \quad \text{con} \quad a = A \cos \varphi, \quad b = A \sin \varphi$$



Regime P.A.S.

■ OPERAZIONI SULLE GRANDEZZE P.A.S.

Nel dominio del tempo:

$$a(t)+b(t); \quad ka(t); \quad \frac{d}{dt}[a(t)]; \quad \int_0^t a(t')dt'$$

Come si trasformano nel
dominio dei fasori ?

Regime P.A.S.

■ OPERAZIONI SULLE GRANDEZZE P.A.S.

Il fasore della somma di due grandezze P.A.S. di uguale ω è la **somma dei fasori delle due grandezze**

$$a(t) = \sqrt{2} \operatorname{Re}(\mathbf{A}e^{j\omega t}) \quad b(t) = \sqrt{2} \operatorname{Re}(\mathbf{B}e^{j\omega t})$$

$$c(t) = a(t) + b(t) = \sqrt{2} \operatorname{Re}(\mathbf{A}e^{j\omega t}) + \sqrt{2} \operatorname{Re}(\mathbf{B}e^{j\omega t}) = \sqrt{2} \operatorname{Re}[(\mathbf{A} + \mathbf{B})e^{j\omega t}] = \sqrt{2} \operatorname{Re}(\mathbf{C}e^{j\omega t}) \quad \text{con } \mathbf{C} = \mathbf{A} + \mathbf{B}$$

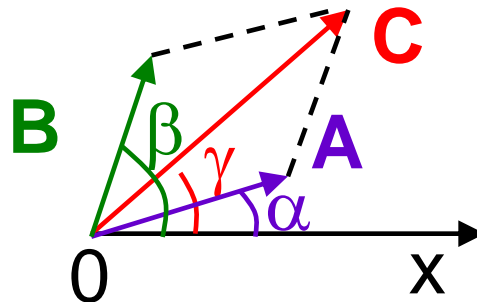

$$\mathbf{A} = Ae^{j\alpha}$$

$$\mathbf{B} = Be^{j\beta}$$



Somma di due fasori

Risulta (regola del parallelogramma):

$$Ce^{j\gamma} = Ae^{j\alpha} + Be^{j\beta}$$

$$C = \sqrt{A^2 + B^2 + 2AB \cos(\alpha - \beta)}$$

$$\tan \gamma = \frac{A \sin \alpha + B \sin \beta}{A \cos \alpha + B \cos \beta}$$



Regime P.A.S.

■ OPERAZIONI SULLE GRANDEZZE P.A.S.

Il fasore del prodotto di una costante scalare per una grandezza P.A.S. è il **prodotto della costante per il fasore della grandezza** stessa

$$a(t) = \operatorname{Re}(\mathbf{A}e^{j\omega t}) \quad \mathbf{A} = Ae^{j\alpha} = a_1 + ja_2$$

$$a(t) = \sqrt{2}A \cos(\omega t + \alpha)$$

$$b(t) = ka(t) = \sqrt{2}kA \cos(\omega t + \alpha)$$

$$\mathbf{B} = k\mathbf{A} = b_1 + jb_2 = ka_1 + jka_2$$

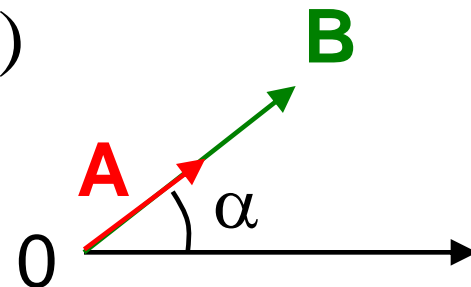



Regime P.A.S.

■ OPERAZIONI SULLE GRANDEZZE P.A.S.

Il fasore della derivata di una grandezza P.A.S. è $j\omega$ per il fasore della grandezza

$$a(t) = \sqrt{2} \operatorname{Re}(\mathbf{A}e^{j\omega t}) \quad \mathbf{A} = Ae^{j\alpha} = a_1 + ja_2$$

$$\begin{aligned} b(t) &= \frac{d}{dt} a(t) = \frac{d}{dt} \left[\operatorname{Re}(\sqrt{2} \mathbf{A}e^{j\omega t}) \right] = \frac{d}{dt} \left[\operatorname{Re}(\sqrt{2} Ae^{j(\omega t + \alpha)}) \right] = \\ &= \frac{d}{dt} \left[\sqrt{2} A \cos(\omega t + \alpha) \right] = -\sqrt{2} A \omega \sin(\omega t + \alpha) = \end{aligned}$$

Regime P.A.S.

■ OPERAZIONI SULLE GRANDEZZE P.A.S.

$$= \sqrt{2}A\omega \cos\left(\frac{\pi}{2} + \omega t + \alpha\right) = \operatorname{Re}\left[\omega\sqrt{2}Ae^{j(\omega t + \alpha)}e^{j\pi/2}\right] =$$

$$= \operatorname{Re}\left[j\omega\sqrt{2}Ae^{j(\omega t + \alpha)}\right] = \sqrt{2} \operatorname{Re}\left[j\omega Ae^{j\omega t}\right] = \sqrt{2} \operatorname{Re}\left[Be^{j\omega t}\right]$$

$$\mathbf{B} = B e^{j\beta}$$

$$\mathbf{B} = j\omega \mathbf{A} = j\omega(a_1 + ja_2) = -\omega a_2 + j\omega a_1$$

$$\beta - \alpha = \pi/2$$

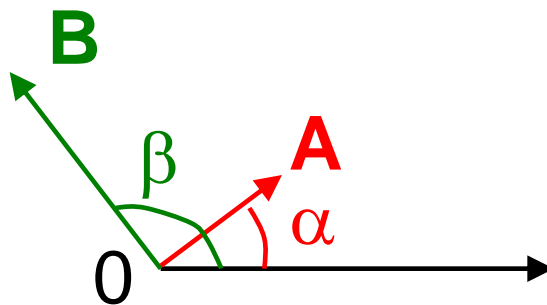



Regime P.A.S.

■ OPERAZIONI SULLE GRANDEZZE P.A.S.

Il fasore dell'integrale di una grandezza P.A.S. è **$1/j\omega$ per il fasore della grandezza**

$$a(t) = \sqrt{2}A \cos(\omega t + \alpha) = \sqrt{2} \operatorname{Re}(\mathbf{A}e^{j\omega t}) \quad \mathbf{A} = Ae^{j\alpha} = a_1 + ja_2$$

$$b(t) = \int_0^t a(t') dt' = \sqrt{2} \frac{A}{\omega} \cos(\omega t + \alpha - \frac{\pi}{2}) \quad \mathbf{B} = Be^{j\beta} = b_1 + jb_2$$

$$b(t) = \sqrt{2} \operatorname{Re} \left[\frac{1}{\omega} A e^{j(\omega t + \alpha - \frac{\pi}{2})} \right] = \sqrt{2} \operatorname{Re} [\mathbf{B} e^{j\omega t}]$$

Regime P.A.S.

■ OPERAZIONI SULLE GRANDEZZE P.A.S.

$$\mathbf{B} = -j\mathbf{A}/\omega = (1/j\omega)(a_1 + ja_2) = a_2/\omega - ja_1/\omega$$

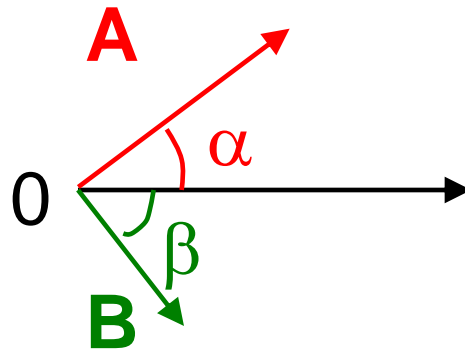

$$\mathbf{B} = \mathbf{A}/(j\omega) = -j\mathbf{A}/\omega$$

$$\alpha - \beta = \pi/2$$

Regime P.A.S.

■ BIPOLI ELEMENTARI IN REGIME P.A.S.

Generatore ideale di tensione

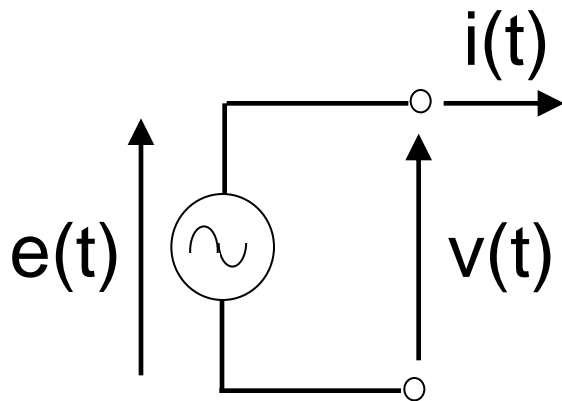

OL per valori istantanei

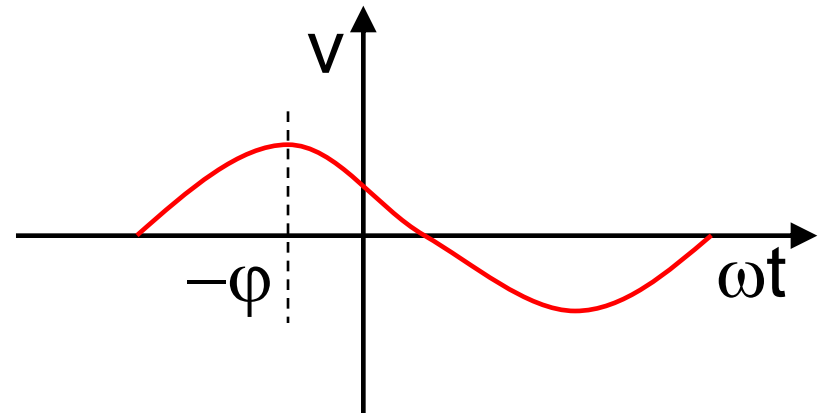

$$v(t) = e(t) = \sqrt{2}E \cos(\omega t + \varphi)$$

OL per fasori

$$\mathbf{V} = \mathbf{E}$$

$$\mathbf{V} = \mathbf{E} =$$

$$= E \angle \varphi$$

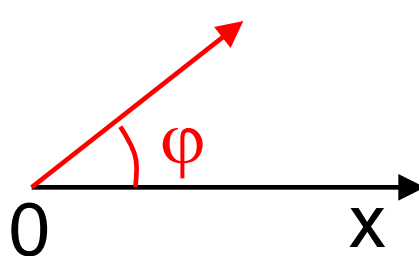

Regime P.A.S.

■ BIPOLI ELEMENTARI IN REGIME P.A.S.

Generatore ideale di corrente

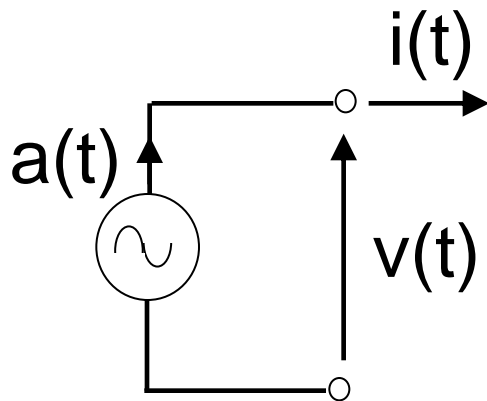

OL per valori istantanei

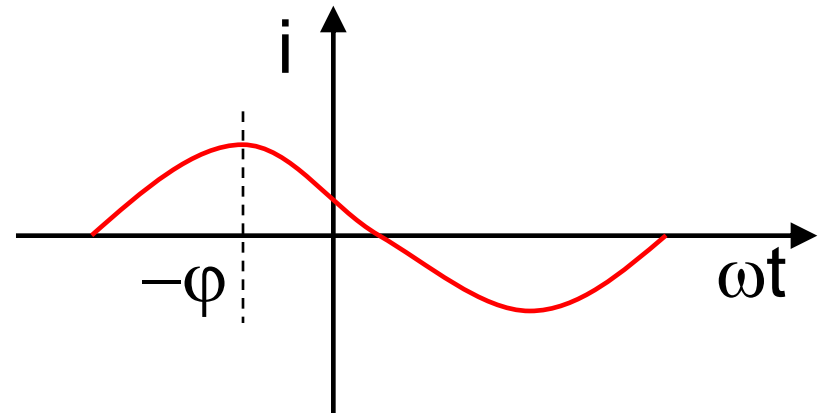

$$i(t) = a(t) = \sqrt{2}A \cos(\omega t + \varphi)$$

OL per fasori

$$\mathbf{I} = \mathbf{A} =$$

$$= A \angle \varphi$$

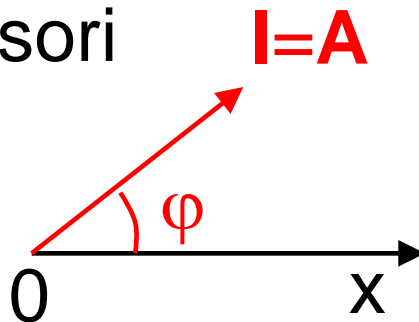

Regime P.A.S.

■ BIPOLI ELEMENTARI IN REGIME P.A.S.

Resistore ideale normale

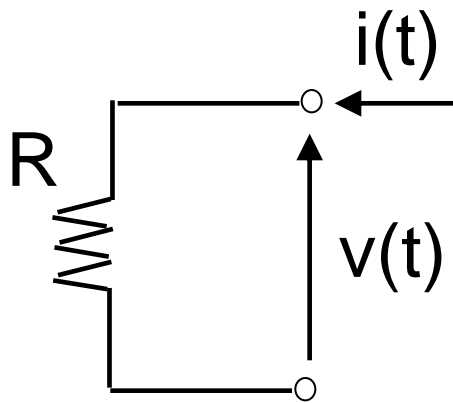

OL per valori istantanei

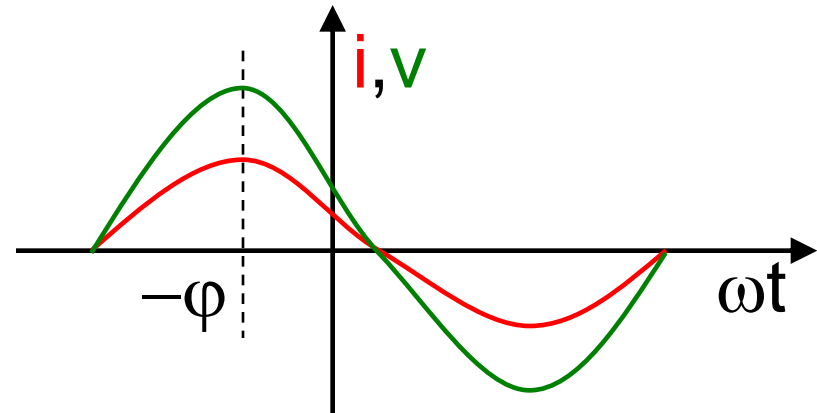

$$v(t) = Ri(t) = R\sqrt{2}I \cos(\omega t + \varphi)$$

OL per fasori

$$\mathbf{V} = R\mathbf{I} =$$

$$= R\mathbf{I} \angle \varphi$$

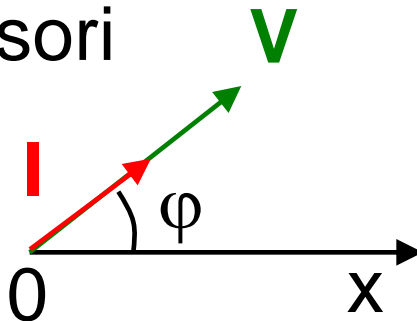

Regime P.A.S.

■ BIPOLI ELEMENTARI IN REGIME P.A.S.

Induttore ideale normale

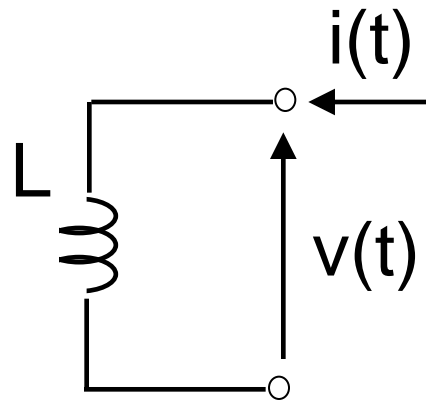

OL per fasori

$$\mathbf{V} = j\omega L \mathbf{I} = \omega L \angle \varphi + \pi/2$$

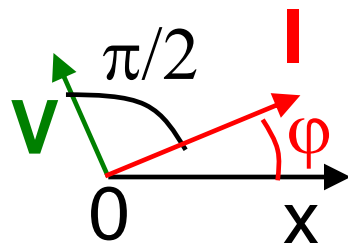

OL per valori istantanei

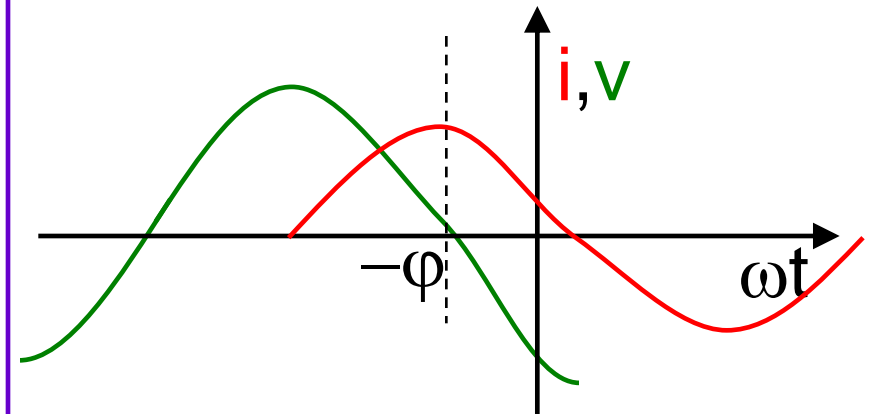

$$v(t) = L \frac{d}{dt} i(t) = L\omega\sqrt{2}I \cos(\omega t + \varphi + \frac{\pi}{2})$$

Regime P.A.S.

■ BIPOLI ELEMENTARI IN REGIME P.A.S.

Condensatore ideale normale

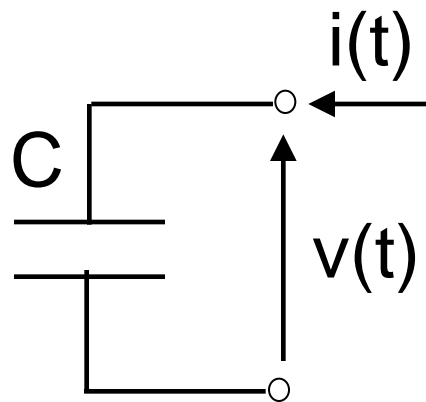

OL per valori istantanei

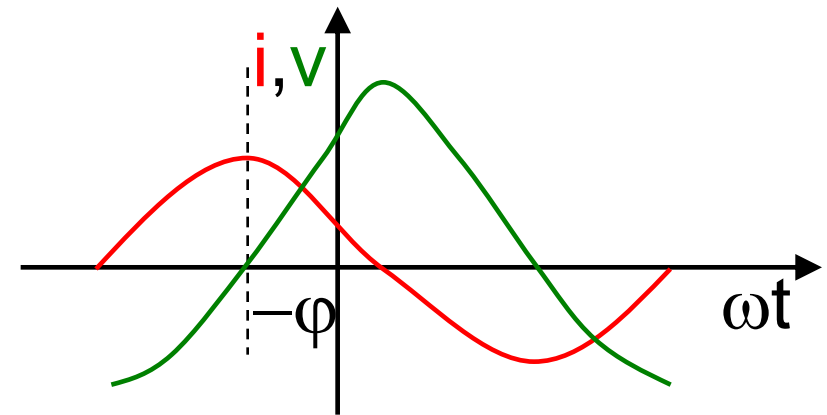

OL per fasori

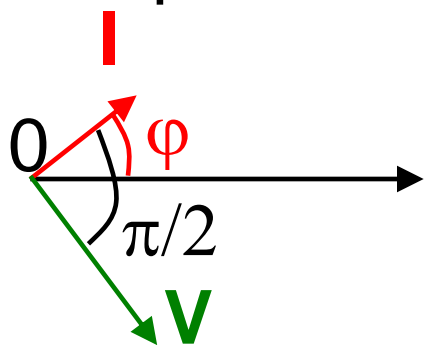

$$\mathbf{V} = -\frac{j}{\omega C} \mathbf{I} = \frac{I}{\omega C} \angle \varphi - \frac{\pi}{2}$$

$$v(t) = \frac{1}{C} \int_0^t i(t') dt' = \frac{1}{\omega C} \sqrt{2} I \cos(\omega t + \varphi - \frac{\pi}{2})$$



Regime P.A.S.

■ **IMPEDENZA** DI UN BIPOLO PASSIVO LINEARE

Per i tre bipoli passivi elementari (R, L, C) e per un qualunque bipolo passivo e lineare è possibile scrivere la legge di Ohm in forma unica e compatta?

La risposta è affermativa nel dominio dei fasori

$$V = R I$$

$$V = j\omega L I$$

$$V = -j/(\omega C) I$$



Regime P.A.S.

■ **IMPEDENZA** DI UN BIPOLO PASSIVO LINEARE

Operatore fasore che moltiplicato per il fasore I fornisce il fasore V .

$$\mathbf{V} = \mathbf{Z} \mathbf{I}$$

$$\mathbf{Z} = R + jX \quad R \text{ resistenza } [\Omega] \quad X \text{ reattanza } [\Omega]$$

$$Z = \sqrt{R^2 + X^2} \quad \varphi = \arctan \frac{X}{R} \quad \mathbf{Z} = Z e^{j\varphi} = Z \angle \varphi$$

$$V e^{j\varphi_v} = Z e^{j\varphi} I e^{j\varphi_i} \quad \varphi = \varphi_v - \varphi_i$$



Regime P.A.S.

■ **AMMETTENZA** DI UN BIPOLO PASSIVO LINEARE

Operatore fasore che moltiplicato per il fasore V fornisce il fasore I .

$$I = Y V \quad \text{evidentemente } Y = 1/Z$$

$$Y = G + jB$$

G conduttanza
[Ω^{-1}] o [S]

B suscettanza
[Ω^{-1}] o [S]



Regime P.A.S.

■ DA IMPEDENZA AD AMMETTENZA

$$\mathbf{Z} = R + jX = Z \angle \varphi$$

$$\mathbf{Y} = \frac{1}{R + jX} \frac{R - jX}{R - jX} = \frac{R - jX}{R^2 + X^2}$$

$$\mathbf{Y} = \frac{R}{R^2 + X^2} - j \frac{X}{R^2 + X^2} = G + jB$$



Regime P.A.S.

■ DA IMPEDENZA AD AMMETTENZA

cartesiana

$$G = \frac{R}{R^2 + X^2} \quad B = -\frac{X}{R^2 + X^2}$$

polare

$$Y = \sqrt{G^2 + B^2} = \sqrt{\frac{R^2 + X^2}{(R^2 + X^2)^2}} = \frac{1}{\sqrt{R^2 + X^2}} = \frac{1}{Z}$$

$$\vartheta = \tan^{-1}\left(\frac{B}{G}\right) = \tan^{-1}\left(-\frac{X}{R}\right) = -\tan^{-1}\left(\frac{X}{R}\right) = -\varphi$$



Regime P.A.S.

■ TABELLA DELLE IMPEDENZE ELEMENTARI

	OL	Z	R	X	Z	φ
resistore	$V=RI$	R	R	0	R	0
induttore	$V=j\omega LI$	$j\omega L$	0	ωL	ωL	$+\frac{\pi}{2}$
condensatore	$V=\frac{-j}{\omega C} I$	$\frac{-j}{\omega C}$	0	$\frac{-1}{\omega C}$	$\frac{1}{\omega C}$	$-\frac{\pi}{2}$



Regime P.A.S.

■ TABELLA DELLE AMMETTENZE ELEMENTARI

	OL	Y	G	B	Y	θ
resistore	$I=V/R$	$\frac{1}{R}$	$\frac{1}{R}$	0	$\frac{1}{R}$	0
induttore	$I= \frac{-j}{\omega L} V$	$\frac{-j}{\omega L}$	0	$\frac{-1}{\omega L}$	$\frac{1}{\omega L}$	$-\frac{\pi}{2}$
condensatore	$I=j\omega CV$	$j\omega C$	0	ωC	ωC	$+\frac{\pi}{2}$

Regime P.A.S.

■ CIRCUITI ELETTRICI IN REGIME P.A.S.

CIRCUITO ELETTRICO = CONNESSIONE DI BIPOLI ELEMENTARI

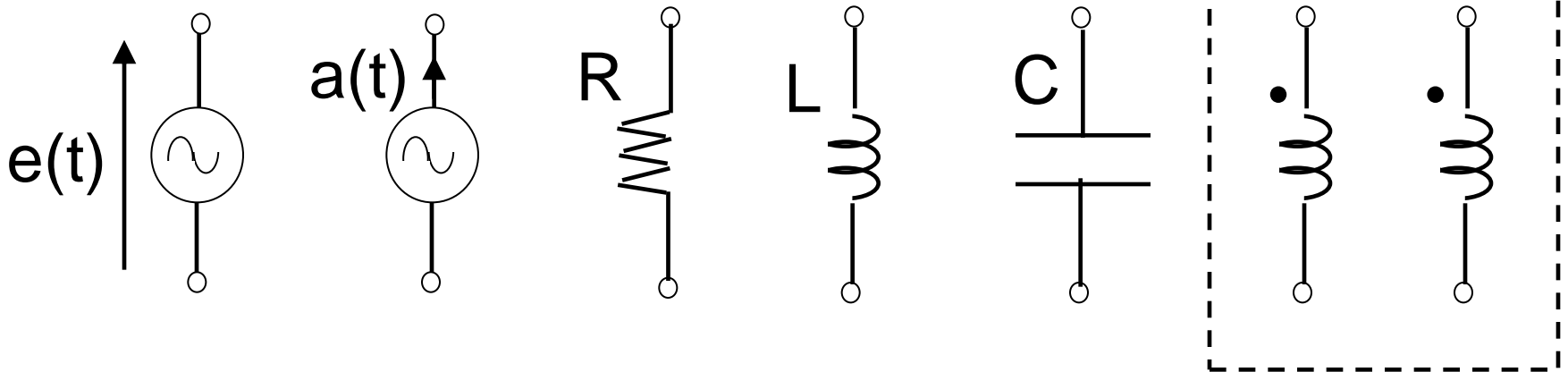

Doppio bipolo –
mutuo induttore



Regime P.A.S.

■ CIRCUITI ELETTRICI IN REGIME P.A.S.

ANALISI DEL CIRCUITO

Noti $e(t)$, $a(t)$, R , L , C

ricavare $v(t)$, $i(t)$ per il generico bipolo

Supponiamo il circuito lineare (R , L , C costanti)

Se $e(t)$, $a(t)$ hanno uguale ω ,
allora anche $v(t)$, $i(t)$ hanno uguale ω

Se $e(t)$, $a(t)$ hanno diversa ω ,
si usa la sovrapposizione degli effetti



Regime P.A.S.

■ CIRCUITI ELETTRICI IN REGIME P.A.S.

STRUMENTI RISOLUTIVI

Dominio del tempo

Dominio dei fasori

OL

$$v=v(i)$$

$$\mathbf{V}=\mathbf{E}+\mathbf{Z}(\mathbf{I}-\mathbf{A})$$

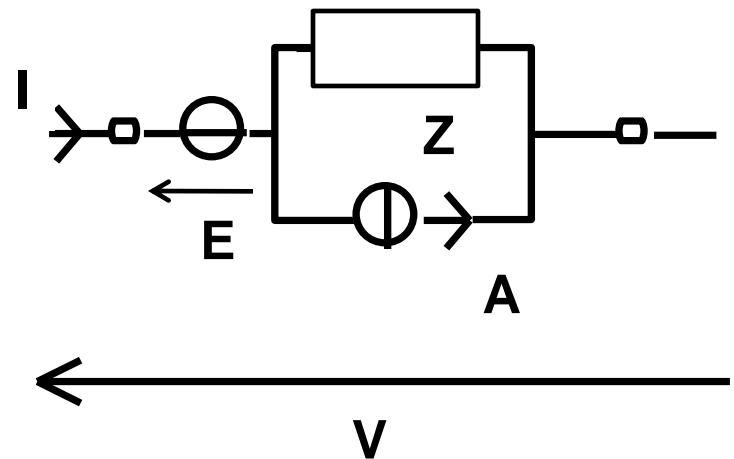



Regime P.A.S.

■ CIRCUITI ELETTRICI IN REGIME P.A.S.

STRUMENTI RISOLUTIVI

Dominio del tempo

Dominio dei fasori

KVL

$$\sum_i v_i(t) = 0$$

$$\sum_i \mathbf{V}_i = 0$$

KCL

$$\sum_i i_i(t) = 0$$

$$\sum_i \mathbf{I}_i = 0$$



Regime P.A.S.

■ CIRCUITI ELETTRICI IN REGIME P.A.S.

PROCEDURA RISOLUTIVA

1. TRASFORMAZIONE

da dominio di t	\Rightarrow	a dominio dei fasori
a, e, v, i	\Rightarrow	A, E, V, I
R, L, C		Z

2. RISOLUZIONE

Nel dominio dei fasori, applicando OL, KVL, KCL e metodi di analisi



Regime P.A.S.

■ CIRCUITI ELETTRICI IN REGIME P.A.S.

PROCEDURA RISOLUTIVA

3. ANTITRASFORMAZIONE

da dominio dei fasori \Rightarrow a dominio di t

V, I \Rightarrow v, i

Regime P.A.S.

■ POTENZA IN REGIME P.A.S.

Si consideri un bipolo, passivo o attivo, lineare

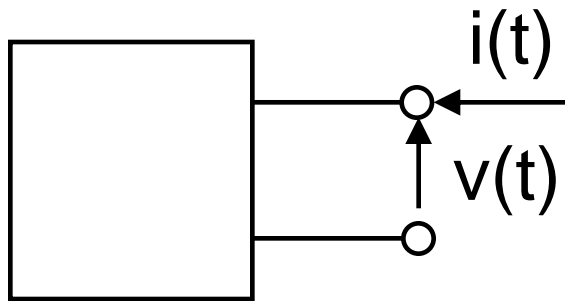

$$p(t) = v(t) i(t)$$

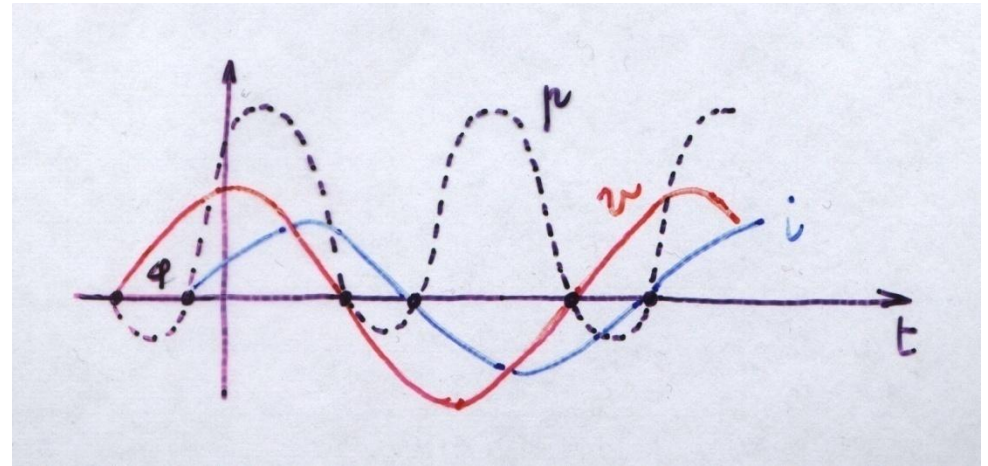

$$v(t) = \sqrt{2}V \cos(\omega t)$$

$$i(t) = \sqrt{2}I \cos(\omega t - \varphi) = \sqrt{2}I [\cos(\omega t) \cos(\varphi) + \sin(\omega t) \sin(\varphi)]$$



Regime P.A.S.

■ POTENZA IN REGIME P.A.S.

$$p(t) = v(t)i(t) = 2VI \cos^2(\omega t) \cos(\varphi) + 2VI \sin(\omega t) \sin(\varphi) \cos(\omega t)$$

poichè

$$\cos^2 x = \frac{1 + \cos(2x)}{2}$$

$$2 \sin(x) \cos(x) = \sin(2x)$$

$$p(t) = VI \cos(\varphi) [1 + \cos(2\omega t)] + VI \sin(2\omega t) \sin(\varphi)$$

$$= p_1(t) + p_2(t) = VI \cos(\varphi) + VI \cos(2\omega t - \varphi)$$

è periodica, sinusoidale, di frequenza $2f$, di valor medio $VI \cos(\varphi)$

Regime P.A.S.

■ POTENZA IN REGIME P.A.S.

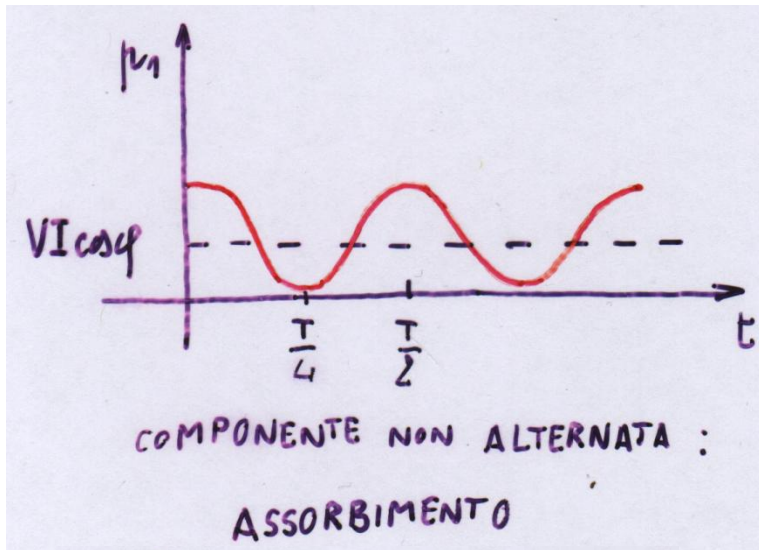

$$p_1(t) = VI \cos(\varphi) [1 + \cos(2\omega t)]$$

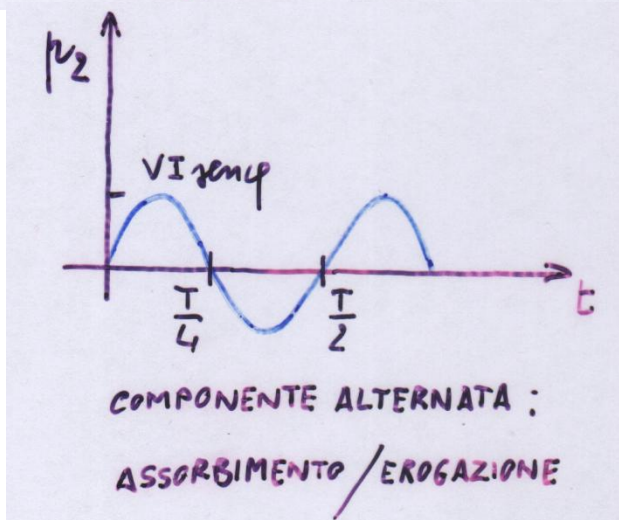

$$p_2(t) = VI \sin(\varphi) \sin(2\omega t)$$



Regime P.A.S.

■ POTENZA IN REGIME P.A.S.

Si definiscono **POTENZA ATTIVA P**

Il valor medio di $p(t)$ o $p_1(t)$: corrisponde alla potenza elettrica scambiata con l'esterno e convertita in potenza non elettrica

$$P \text{ [W]} \quad P = V I \cos(\varphi) \rightarrow \text{fattore di potenza}$$

Energia assorbita in un periodo

$$E = \int_0^T p dt = T \frac{1}{T} \int_0^T p dt = TVI \cos(\varphi) = TP$$



Regime P.A.S.

■ POTENZA IN REGIME P.A.S.

POTENZA REATTIVA Q

Il valor massimo di $p_2(t)$ corrisponde alla potenza elettrica alternativamente assorbita ed erogata

$$Q \text{ [VAR]} \quad Q = V I \sin(\varphi)$$

MISURA DI P

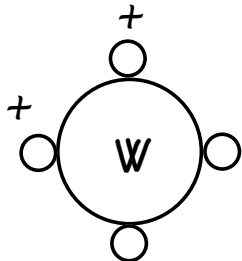

MISURA DI Q

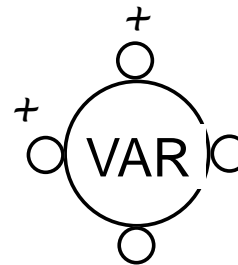

Regime P.A.S.

■ POTENZA IN REGIME P.A.S.

POTENZA APPARENTE \mathbf{A}

La potenza apparente è un fasore

$$\mathbf{A} = (A, \varphi) = (VI, \varphi)$$

Come ottenere \mathbf{A} da \mathbf{V} e \mathbf{I} ?

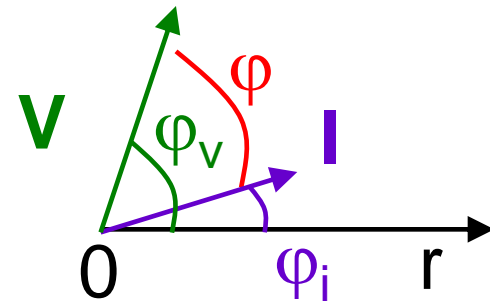

E' forse $\mathbf{A} = \mathbf{V} \mathbf{I}$?

$$\mathbf{A} = V e^{j\varphi_v} I e^{j\varphi_i} = VI e^{j(\varphi_v + \varphi_i)}$$

NO!

Regime P.A.S.

■ POTENZA IN REGIME P.A.S.

E' forse $\mathbf{A} = \mathbf{V} \mathbf{I}^*$?

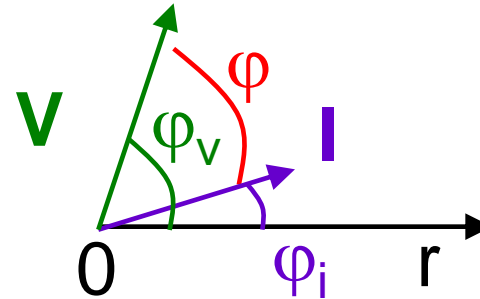

$$\mathbf{A} = \mathbf{V} e^{j\varphi_v} \mathbf{I} e^{-j\varphi_i} = \mathbf{V} \mathbf{I} e^{j(\varphi_v - \varphi_i)} \quad \mathbf{Sì!}$$

$$P = \text{Re} [\mathbf{V} \mathbf{I}^*]$$

$$Q = \text{Im} [\mathbf{V} \mathbf{I}^*]$$

Regime P.A.S.

■ RAPPRESENTAZIONE GRAFICA DELLE POTENZE

TRIANGOLO DELLE POTENZE

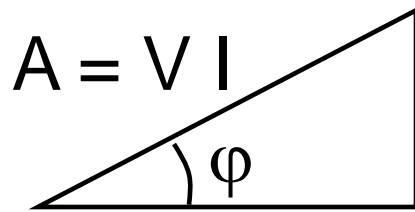

$$Q = V I \sin(\varphi)$$

$$\varphi = \tan^{-1} \frac{Q}{P}$$

$$P = V I \cos(\varphi)$$

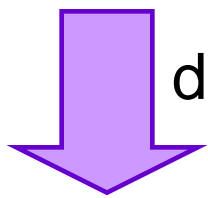

dividendo per I

TRIANGOLO DELLE TENSIONI

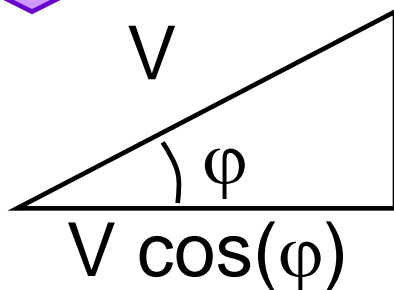

$$V \sin(\varphi)$$

Regime P.A.S.

■ RAPPRESENTAZIONE GRAFICA DELLE POTENZE

TRIANGOLO DELLE TENSIONI

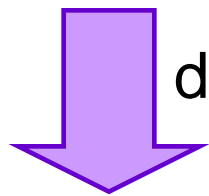

dividendo per I

TRIANGOLO DELL'IMPEDENZA

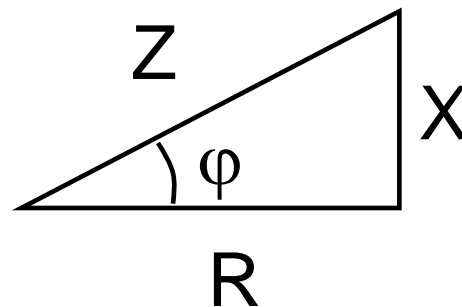



Regime P.A.S.

■ **SEGNI DELLE POTENZE (CONVENZIONE UTILIZZATORI)**

$$|\varphi| = |\varphi_v - \varphi_i| < \frac{\pi}{2} \quad P = VI \cos(\varphi) > 0 \quad \text{assorbimento}$$

$$|\varphi| > \frac{\pi}{2} \quad P = VI \cos(\varphi) < 0 \quad \text{erogazione}$$

$\varphi > 0$ V in anticipo su I $Q > 0$ **INDUTTIVA**

$\varphi < 0$ V in ritardo su I $Q < 0$ **CAPACITIVA**



Regime P.A.S.

■ **SEGNI DELLE POTENZE**

OSSERVAZIONE – Se si assegna $\cos(\varphi)$ in luogo di φ , occorre precisare



$$\cos(\varphi)_R \text{ (I in ritardo)} \quad \varphi > 0$$

$$\cos(\varphi)_A \text{ (I in anticipo)} \quad \varphi < 0$$

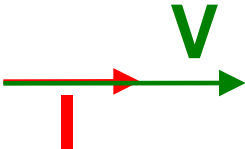

Regime P.A.S.

■ POTENZE PER I BIPOLI PASSIVI ELEMENTARI

	FASORI	OL	φ	P	Q
resistore		$V = R I$	0	$VI = RI^2$ $= V^2/R$	0
induttore		$V = X I$	$+\frac{\pi}{2}$	0	$VI = XI^2 =$ V^2/X
condensatore		$V = X I$	$-\frac{\pi}{2}$	0	$-VI =$ $- X I^2 =$ $-V^2/ X $



Regime P.A.S.

■ TEOREMA DELLA CONSERVAZIONE DELLA POTENZA ATTIVA E REATTIVA (BOUCHEROT)

Vale per circuiti lineari in regime P.A.S.

se

V_i fasori delle tensioni di lato soddisfacenti KVL

I_i fasori delle correnti di lato soddisfacenti KCL

allora $\sum_i V_i I_i^* = 0, \quad i=1, \ell$

ovvero $\sum_i \operatorname{Re}[V_i I_i^*] = \sum_i P_i = 0 \quad i=1, \ell$

$\sum_i \operatorname{Im}[V_i I_i^*] = \sum_i Q_i = 0 \quad i=1, \ell$



Regime P.A.S.

■ MASSIMO TRASFERIMENTO DI POTENZA ATTIVA DA GENERATORE A CARICO ATTRAVERSO UNA LINEA

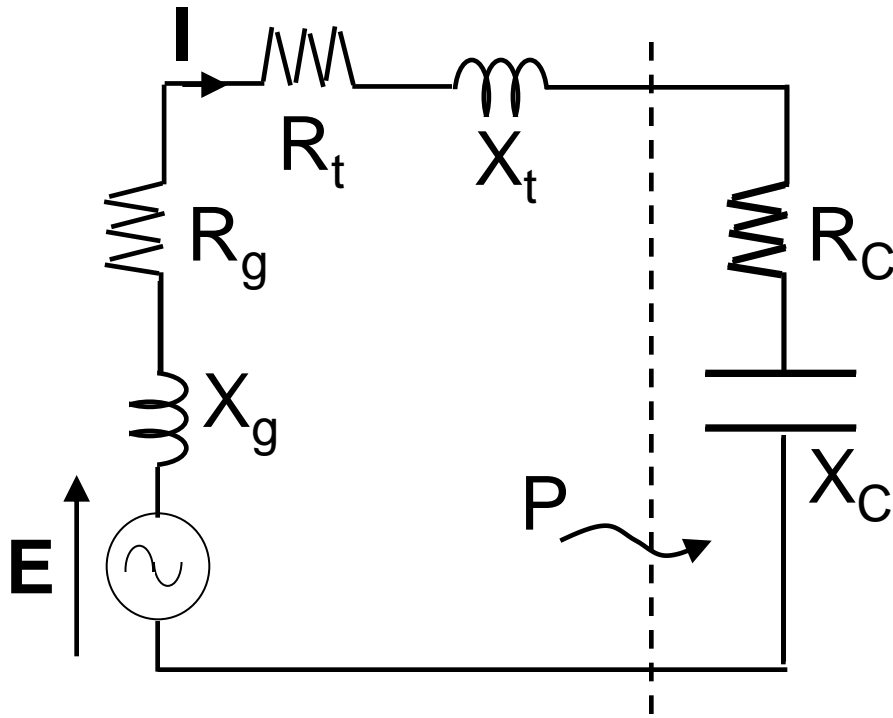

PROBLEMA:

noti \mathbf{E} , R_g , X_g , R_t , X_t ,

Qual è il valore di $\mathbf{Z}_C = R_C + jX_C$ affinché P sia massima?



Regime P.A.S.

■ MASSIMO TRASFERIMENTO DI POTENZA ATTIVA DA GENERATORE A CARICO ATTRAVERSO UNA LINEA

nella maglia $I=E/Z$

$$I = \frac{E}{Z} = \frac{E}{\sqrt{(R_g + R_t + R_c)^2 + (X_g + X_t + X_c)^2}}$$

potenza attiva assorbita dal carico

$$P = R_c I^2 = \frac{R_c E^2}{(R_g + R_t + R_c)^2 + (X_g + X_t + X_c)^2}$$



Regime P.A.S.

■ MASSIMO TRASFERIMENTO DI POTENZA ATTIVA DA GENERATORE A CARICO ATTRAVERSO UNA LINEA

affinchè P sia massima

$$\text{occorre } (X_g + X_t + X_c)^2 = 0 \quad X_c = -(X_g + X_t)$$

$$P = \frac{R_c E^2}{(R_g + R_t + R_c)^2}$$

$$\frac{\partial P}{\partial R_c} = \frac{(R_g + R_t + R_c) - 2R_c}{(R_g + R_t + R_c)^3} E^2 = 0$$

Regime P.A.S.

■ MASSIMO TRASFERIMENTO DI POTENZA ATTIVA DA GENERATORE A CARICO ATTRAVERSO UNA LINEA

$$R_c = R_g + R_t \quad \text{e, da prima,} \quad X_c = -(X_g + X_t)$$

$$Z = R_g + R_t + j(X_g + X_t)$$

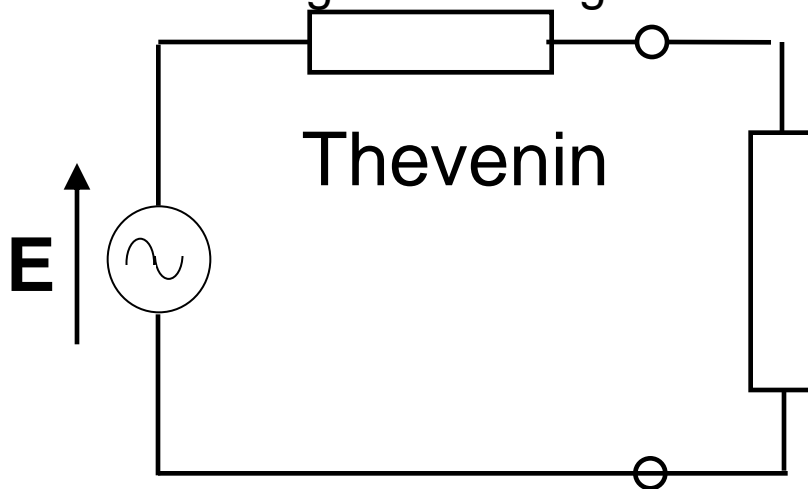

$$Z_c = Z^*$$

$$P_{\max} = \frac{E^2}{4(R_g + R_t)}$$

Generatore e carico
si dicono adattati
energeticamente

Regime P.A.S.

■ RIFASAMENTO

Portare il fattore di potenza di un bipolo
prossimo a 1

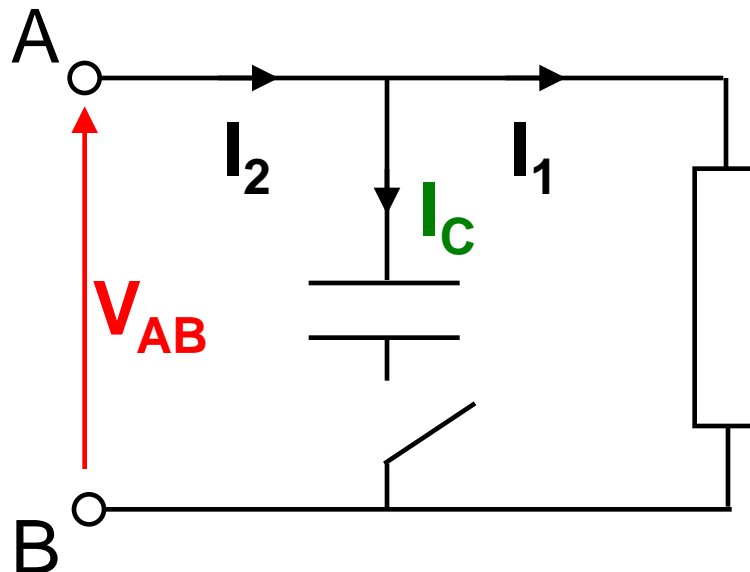

Esempio: rifasare un
carico induttivo a
 $\cos(\varphi)=0.8$ mediante
un condensatore

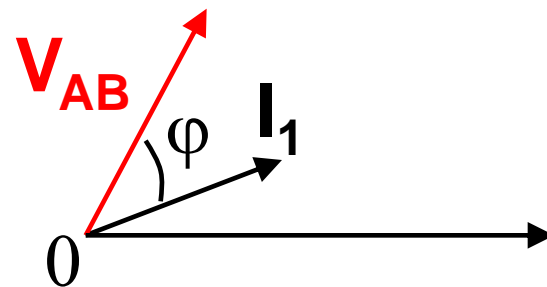

Regime P.A.S.

■ RIFASAMENTO

Le potenze ai morsetti A-B

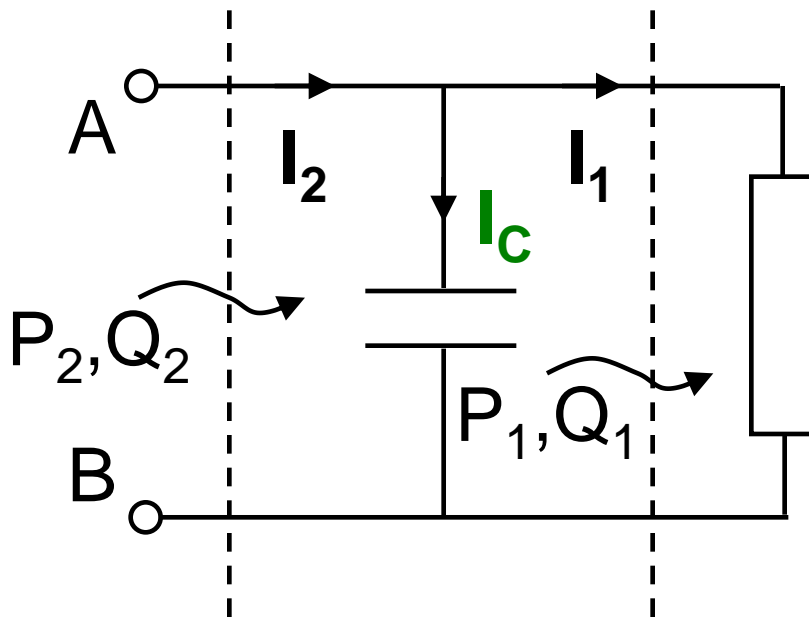

In assenza di C

$$I_1 = I_2, \quad P_1, \quad Q_1$$

In presenza di C

$$I_2 = I_1 + I_c, \quad P_2 = P_1,$$

$$Q_2 = P_2 \tan(\cos^{-1} 0.8)$$



Regime P.A.S.

■ RIFASAMENTO

La potenza Q_c assorbita dal condensatore

$$Q_c = Q_2 - Q_1 < 0$$

$$C = \frac{|P_2 \tan(\cos^{-1} 0.8) - Q_1|}{\omega V_{AB}^2}$$

